

立式高速比多段減速機

VERTICAL, HIGH GEAR RATION & MULTI-STAGE REDUCER

MODEL: LK-SVLS

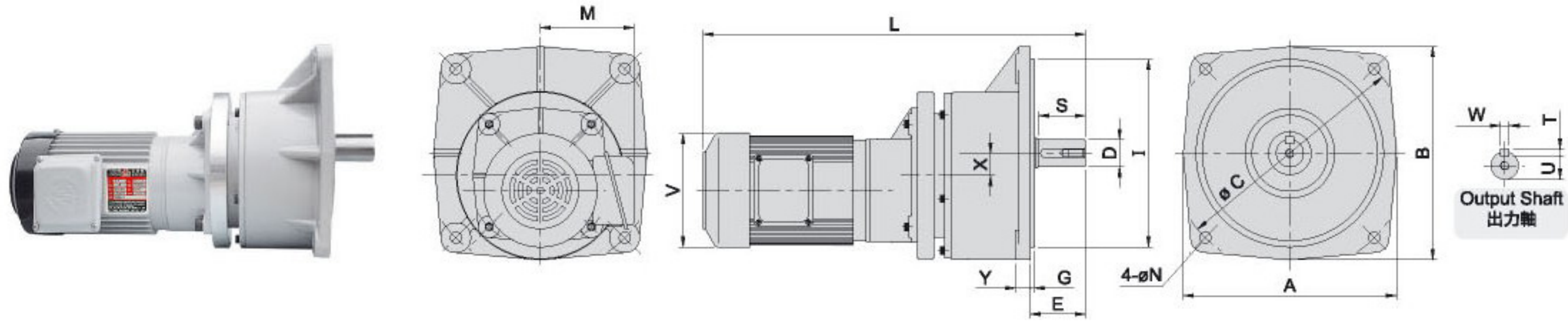

尺寸表 Dimension

單位：m/m

馬達容量 Motor Capacity	型號 Model No.	減速比 Gear Ratio	A	B	C	M	N	I	E	G	Y	X	L	V	出力軸 Output Shaft					重量 Weight (kg)約	
															D	S	W	T	U		
60 W	SV-A11	1/2000	145	145	170	95	11	/	46.5	4	12	18	373	98	22	40	7	7	18	10	
	SV-11		174	174	185	95	11	140	48.5	4	12	18	373	98	22	40	7	7	18	10	
90 W	SV-A11		145	145	170	95	11	/	46.5	4	12	18	388	98	22	40	7	7	18	10	
	SV-11		174	174	185	95	11	140	48.5	4	12	18	388	98	22	40	7	7	18	10	
0.1 KW 1/8HPx4P	12		以上	217	217	235	100	11	180	58	6	15	23	415	119	28	45	7	7	24	12
0.2 KW 1/4HPx4P	13			250	250	280	110	13	220	65	5	17	26	449	133	32	55	10	8	27	18
0.4 KW 1/2HPx4P	14	260		276	310	115	18	230	77	5	20	28	515	147	40	65	10	8	35	35	

註：多速比減速機以定轉速設計，請參考齒箱最大容許扭力。 Note: This multistage gear reducer is designed to rotate at fixed speed. Please refer to the maximum allowable torque of the gear box.